

Artic./Item	Descrizione/Description	Modello/Model
126050	FRIGGITRICE ELETTRICA 8LT 8LT ELECTRIC FRYER	FR35ES/0

Cons./Recom.	Pos./Posit.	Ricambio/Replacement	
	01	RC00418000	ASSIEME CAMINO 350 FLUE ASSEMBLY 350
	02	RC00330000	SUPPORTO CESTELLO FRIGGITRICE SUPPORT FOR BASKET FR
	03	RC00331000	GHIERA CESTELLO BASKET RING NUT
	04	RC00459000	COPERCHIO LID
	05	RC00283000	INTERRUTTORE DI SICUREZZA SAFETY SWITCH
*	06	RC00091000	FERMO BULBO BULB CATCH
	07	RC00333000	MOLLA BULBO BULB SPRING
	08	RC00328000	LEVA SOLLEVAMENTO RESIST. HEATING ELEMENT LIFTING LEVER
*	09	RC00774000	RELE' RELAY
	10	RC00329000	MANOPOLA SCARICO KNOB
*	11	RC02257000	RESISTENZA FRIGGITRICE EL. "SUPER" HEATING ELEMENT
	12	RC00334000	STAFFA RESISTENZE HEATING ELEMENT BRACKET
*	13	RC00281000	TERMOSTATO DI LAVORO WORKING THERMOSTAT
*	14	RC00070000	COMMUTATORE TRIFASE SWITCH
	16	RC00304000	MORSETTO EQUIPOTENZIALE COMP. EQUIPOTENTIAL CONNECTING BLOCK
	17	RC00303000	REGGIFASCETTA CLAMP SUPPORT
	19	RC00241000	PRESSACAVO PG16 CON DADO CABLE GLAND AND NUT
	22	RC00311000	PIEDINO H=25 MM FOOT
	23	RC01002000	FALSO FONDO FRE FALSE-BOTTOM FRE
	24	RC00079000	TUBO DI SCARICO DRAIN PIPE
	25	RC00297000	PASSACAVO FAIRLEAD
*	26	RC00052000	LAMPADA SEGN.NEON FASTON ARANCIO 230V SIGNAL LAMP
*	27	RC01783000	PORTALAMPADA TRASPARENTE D10 TRANSPARENT LAMP HOLDER D10

Artic./Item	Descrizione/Description	Modello/Model
<b>126050</b>	<b>FRIGGITRICE ELETTRICA 8LT 8LT ELECTRIC FRYER</b>	<b>FR35ES/0</b>

Cons./Recom.	Pos./Posit.	Ricambio/Replacement	
	28	RC00194000	MORSETTIERA FV 122 B CONNECTING BLOCK
*	29	RC01782000	LAMPADA SEGN.NEON FASTON VERDE 230V GREEN NEON LAMP 230V
	30	RC00310000	PROTEZIONE LIMITATORE LIMIT SWITCH PROTECTION
*	31	RC00063000	TERMOSTATO DI SICUREZZA SAFETY THERMOSTAT
	32	RC01786000	MANOPOLA FRIGGITRICE ELETTRICA NERA FRE ELECTRIC KNOB
	32	RC02030000	MANOPOLA FRE GRIGIA GREY KNOB
	34	RC00335000	SICURA SCARICO DRAIN SAFETY CATCH
	35	RC00080000	RUBINETTO SCARICO DRAIN COCK FR
*	36	RC00336000	LEVA SCARICO DRAIN LEVER
	37	RC00337000	RACCORDO DIAMETRO 18 CONNECTION DIAMETER 18
	39	RC00322000	PASSACAVO OVALE OVAL FAIRLEAD

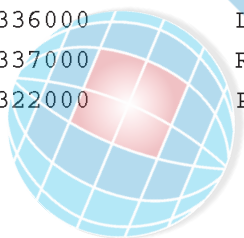

PLATON SERVICE

8 (800) 500-34-41

www.platonservice.com

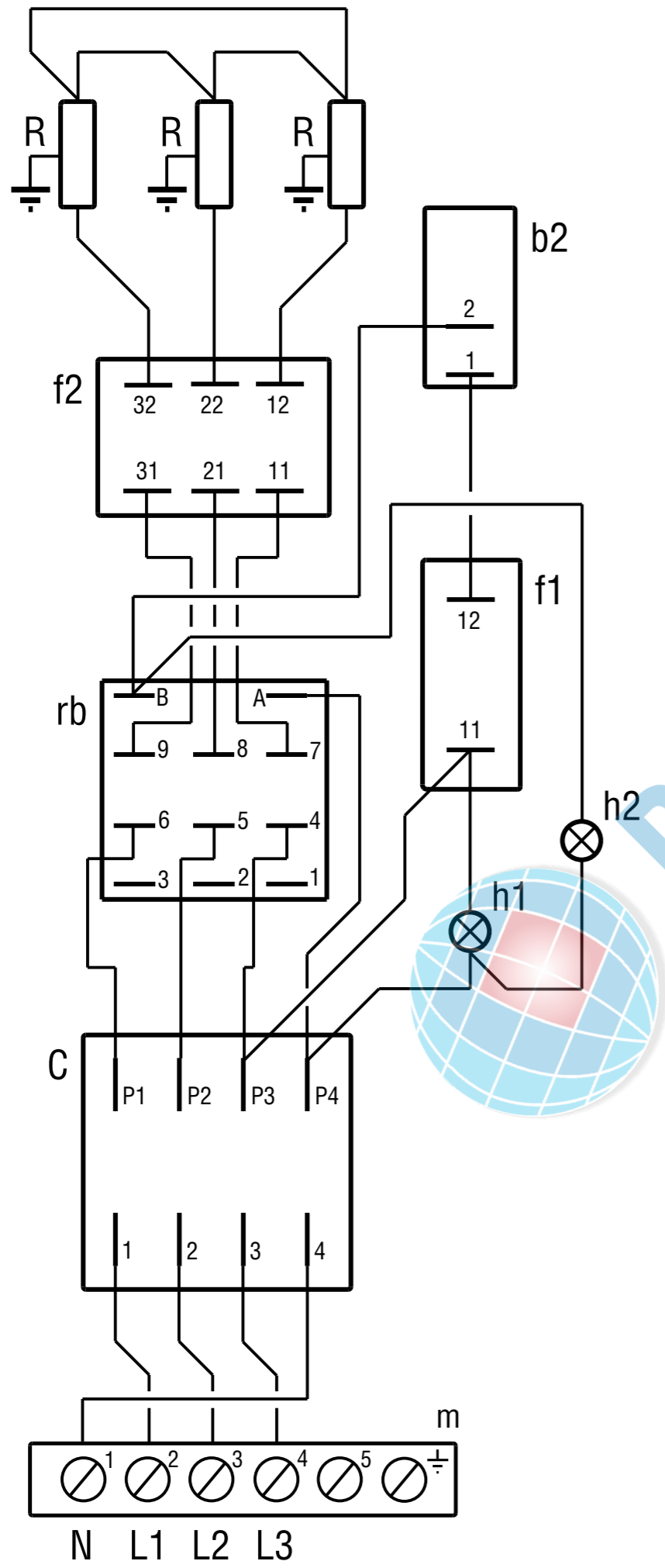

f2	Limitatore di temperatura	Temperature Limiting Device
f1	Termostato di lavoro	Thermostat
b2	Interruttore di sicurezza	Security Switch
h2	Lampada resistenza inserita (arancio)	Running Heating Element Lamp (orange)
h1	Lampada presenza tensione (verde)	Tension Signal Lamp (green)
C	Commutatore	Switch
rb	Relè	Remote control switch
R	Resistenza elettrica	Heating Element
m	Morsettiera	Main Terminal Block

PLATON SERVICE  
 8 (800) 500-3447  
 www.platonservice.com

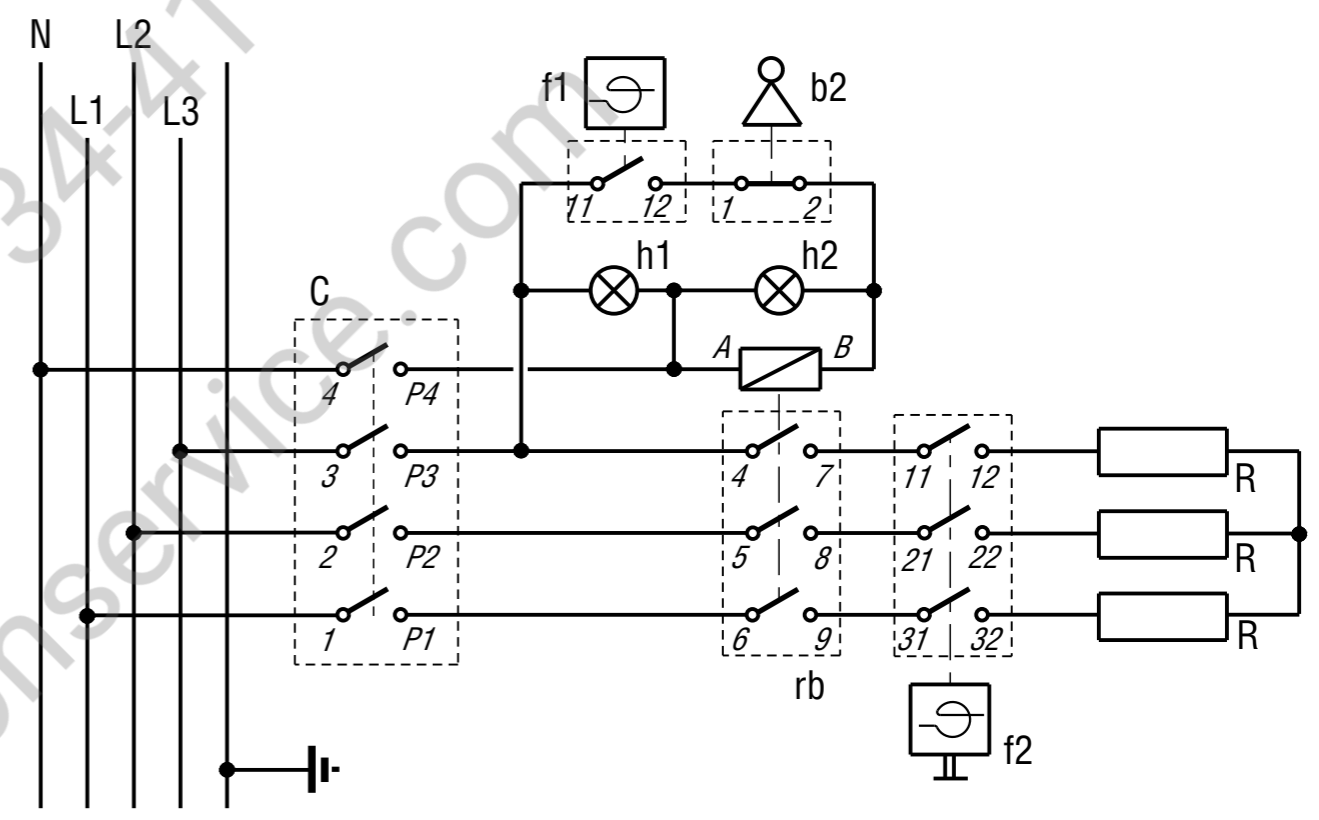

**5415.001.03**  
 SCHEMA ELETTRICO WIRING DIAGRAM  
 400V~3N  
 Mod. DFR35E0 DFR35ES0  
 FRS35E/6/0 FR35ES/6/0  
 FR35E/0 FR35ES/0  
 FR35E7 FR35ES7  
 FR4\_E7 FR4\_ES7